

SANITARY BALL VALVES

FLOWING YOUR ENERGY



NEUMO

NEUMO Ehrenberg Group



INNOVATION
COMMITMENT

COMPANY

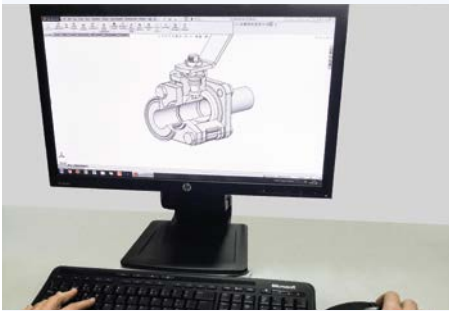

Supplying some of the most demanding end customers for more than 30 years

Index

1 TECHNICAL INFORMATION

4-7

- General Features
- Multiport Configurations
- Optional Fugitive Emission Design
- Optional Firesafe Design
- Optional Cavity Filler Design
- Drainability
- Inline Serviceable
- Welding Properties
- Cleanliness and Packing
- Certifications and Approvals

2 VALVES SERIES

8-17

2- WAY



MULTI PORT



3 OPTIONS

18-19

- Lockable handle
- Stem Extension
- Oval Handle
- Bracket
- Actuator
- Tank Bottom
- CIP/ SIP Purge Port
- Steam trap
- Double Block and Bleed
- Fire Fail Safe

GENERAL FEATURES

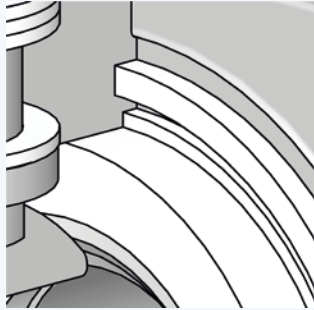

Double encapsulated body seals for extra resistance and tightness performance

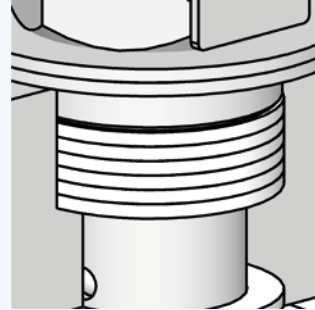

Self-adjust live loaded packing system ensures longer service without maintenance and spare parts replacement

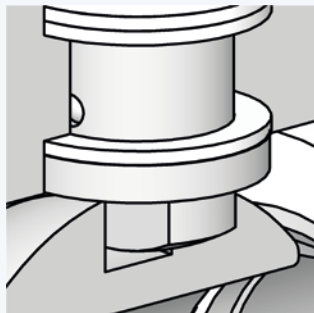

Anti-static device ensures the electrical conductivity between body, end, ball and stem according to european directive 2014/34/EU (ATEX)

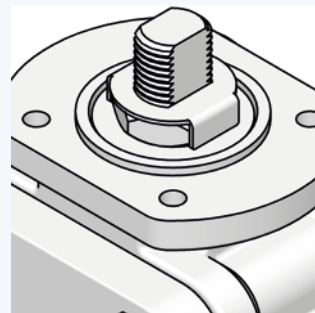

Top flange fitted with ISO 5211 providing universal connection for automation

MULTIPORT CONFIGURATION

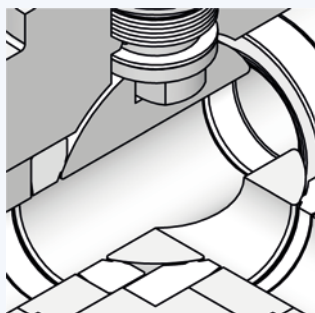

T Port

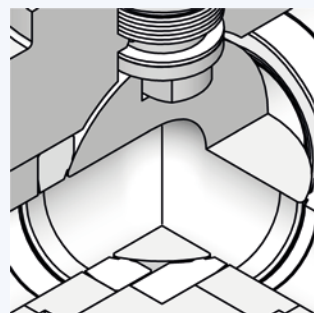

L Port

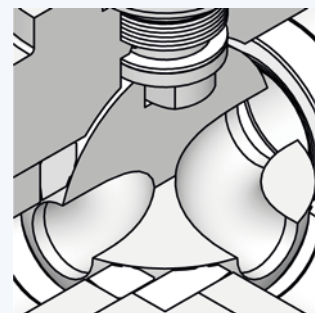

X Port

The multiport design is equipped with four seats to support the ball in any port configuration and provide sealing capabilities to each port independently. This design permits that each multiport valve replaces two or more 2-way valves reducing the number of valves and fittings required.

OPTIONAL FUGITIVE EMISSION DESIGN

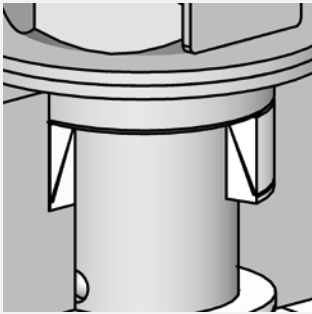

Optional fugitive emissions design according to ISO 15848 and TA LUFT / VDI 2440 reducing the potentially harmful emission to the environment. The upgrade to a "V" shape packing increases the performance of the packing as well as increases the life cycle time. This design is also suitable for vacuum service up to 10^{-6} mm Hg.

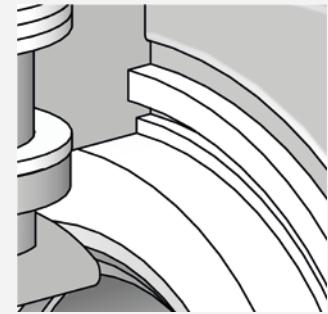

OPTIONAL FIRESAFE DESIGN

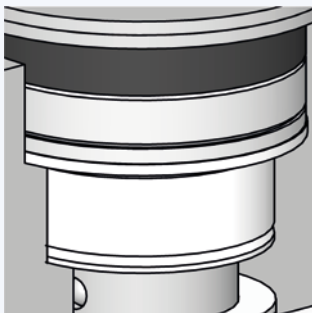

Optional firesafe design according to ISO 10497 and API 607 for critical services. Primary layer of TFE prevents graphite contamination into the media assuring the cleanliness and high purity of the processes.

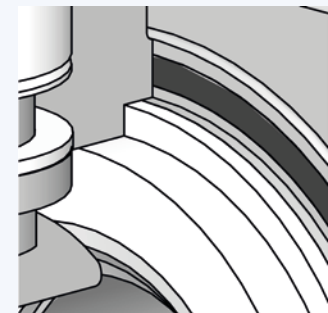

OPTIONAL CAVITY FILLER DESIGN

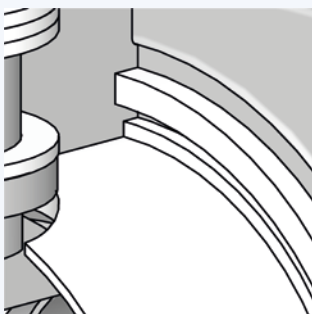

Optional cavity filler design is available to fill in the dead space between the body and the ball. This prevents the media from being trapped reducing the contamination or the solidification of the media enhancing a smooth operation for longer time.

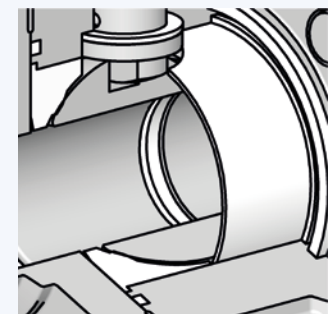

DRAINABILITY

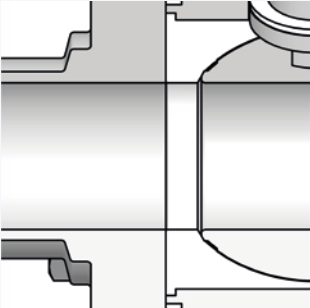

Tube bore version is designed to allow the media to self-drain smoothly due to its unobstructed construction. This improves the flow capacity of the valve and reduces the formation of inlays, pooling effect, dead legs and trapped media in the piping. To achieve this condition, it is important to install the valves assuring the correct slope to benefit from the gravity impulse. It is the cheapest and most effective way to maintain the installations cleaned and drained. The valves can also be equipped with the CIP / SIP design to enhance the cleaning and maintenance program as shown in the options chapter.

INLINE SERVICEABLE

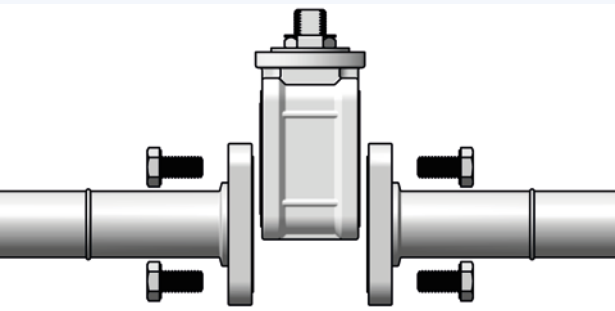

All valves are constructed to allow the inline service which reduces the maintenance costs and the time needed for any intervention.

SUITABILITY FOR CONTACT WITH FOOD STUFF

European Directives:

1935/2004/CE
1895/2005/CE
10/2011/UE

American Regulations:

FDA, Food and Drug Administration, Department of Health and Human Services, Code of Federal Regulations 21 CFR Ch. 1
USA regulations sections 177.1550 (a) (1) and (b)
- Perfluorocarbon Resins

HAZARDOUS SUBSTANCES FOR HEALTH

European Directives:

76/769/EC
2011/65/EU (ROHS)
Directive 2003/11/EC
Directive 2003/53/EC
Directive 2006/122/EC
Directives 2009/251/EC

European Regulations:

EC 1005/2009

Others:

GADSL 2015
BSE / TSE / ADI free

SUITABILITY FOR MEDICAL DEVICES

Directive 93/42/EEC - USP Class VI

WELDING PROPERTIES

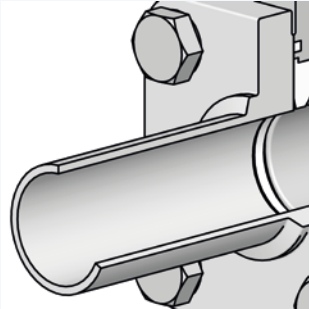

Welding connection material with controlled sulphur content between 0.005 and 0.017% to improve weldability.

Ferrite content below 3% for investment cast and 0.5% for barstock / forging preventing corrosion formation. Butt weld length adapted to allow direct orbital welding process without disassembling the valves.



CLEANLINESS AND PACKING



All valves are degreased, pickled, passivated and cleaned to achieve high levels of cleanliness.

Afterwards this the valves are packed and sealed in individual protective plastic bags with silica to prevent contamination and humidity problems.

Optional degreased for applications as oxygen service available upon request.

CERTIFICATION	CONSTRUCTION STANDARDS	TEST STANDARDS
Company Quality System Certified acc. to ISO 9001 CE PED Certification acc. to 2014/68/EU ATEX Certification acc. to 2014/34/EU Fugitive Emission Class BH acc. to ISO 15848 and TA-LUFT (VDI2440) CO1 (-46°C to 200°) FDA & USP Class VI certificate of compliance for nonmetllic parts	DIN 11850 R2 ISO 1127 ISO 5211	Test applied: Hydrostatic shell and seat test Pneumatic shell and seat test Buroscopic inspection Ra measurement EN10204 type 3.1 certificate is available for each valve EN10204 type 3.2 certificate is available upon request

RP Series

2 Way Floating
Barstock / Forging

The RP Series is a sanitary floating ball valve designed for Pharmaceutical and Food & Beverage applications where high purity, drainability and cleanability are extremely important to ensure high levels of process quality and performance.

Welding connections are provided as standard in A479 316L with controlled sulphur and ferrite content below 0.5% to improve weldability and avoid corrosion.

Non-metallic parts comply with FDA, USP cl VI, ROHS, BSE/TSE and others to guarantee the suitability of the valves to the processes. External and internal mechanical polishing matching SF3 and SF1, provided as standard, makes this high-tech mirror polished series the best solution for maximum cleanliness requirements of the clean room applications.

A better internal mechanical polishing and electropolishing matching SF4 finishing is available upon request.

RP valves are autoclavable at 121 °C x 20 minutes

ASME BPE TUBE (O.D)

Tube Bore: ½" to 6"

DIN 11850 R2 TUBE

Tube Bore: 10 to 50
Full Bore: 65 to 150

ISO 1127 TUBE

Tube Bore: 8 to 50
Full Bore: 10 to 100

DESIGN TEMPERATURE

-50°C to 200°C

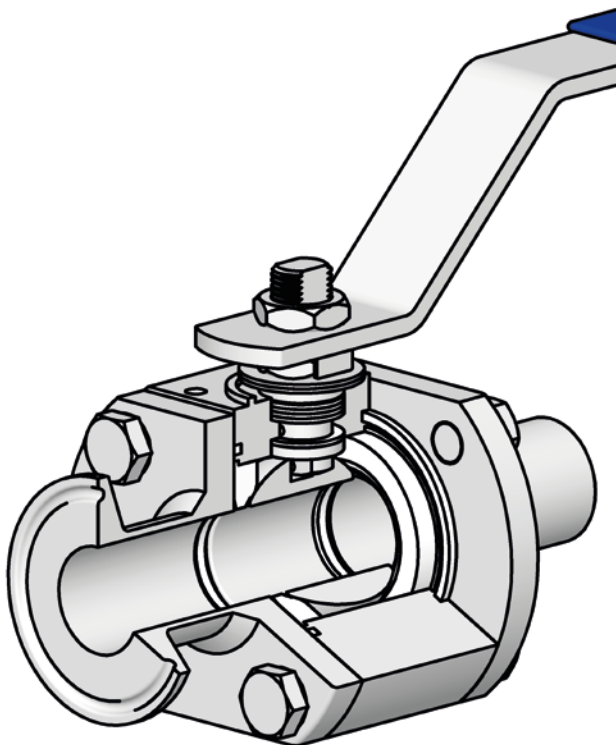

PART		STANDARD STAINLESS STEEL	OPTIONAL* ALLOY STEEL
Body / Ends		A479 316/L	B574 N06022 (Alloy 22)
TRIM	Ball	A479 316/L	B574 N06022 (Alloy 22)
	Stem	A479 316/L	B574 N06022 (Alloy 22)
Seats		TFM1600	
Packing & Seals		TFM1600 & PTFE	
Bolting		A2 cl. 70 (304)	A4 cl. 70 (316)
SURFACE FINISH			
STANDARD		OPTIONAL	
INTERNAL FINISH 0.51 µm / 20 µin (SF1)		INTERNAL FINISH 0.38 µm / 15 µin (SF4)	
EXTERNAL FINISH 0.76 µm / 30 µin (SF3)			

*Others available upon request

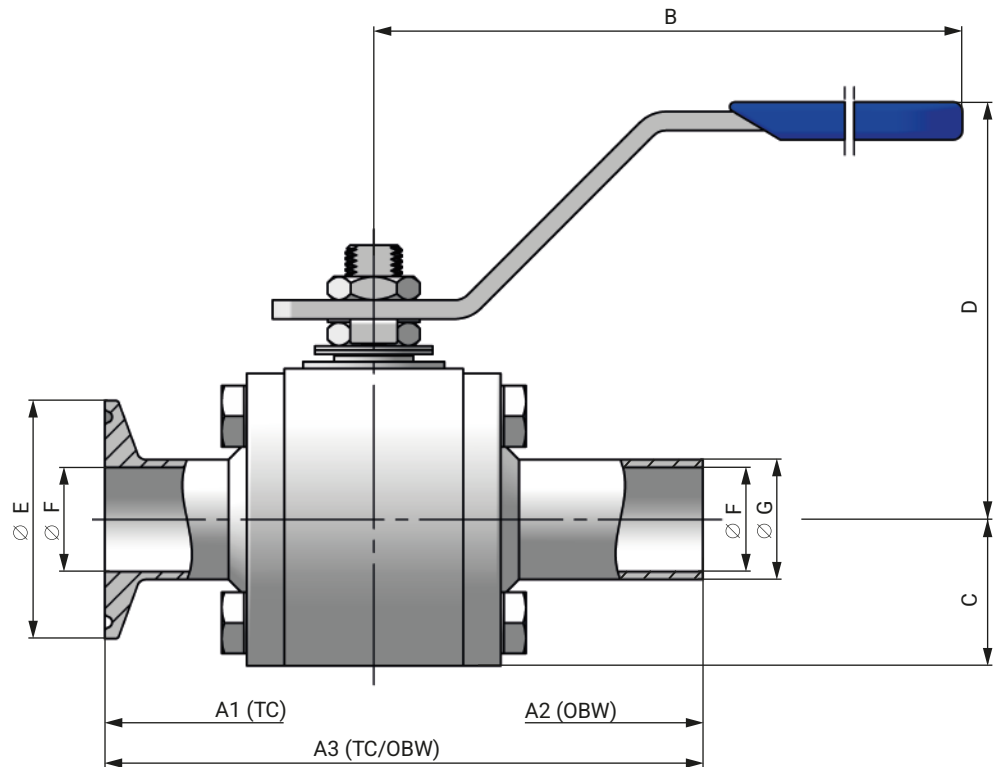

ASME	CLASS	BORE	A1	A2	A3	B	C	D	E	F	G	kg	ISO 5211
½"	600	9.4	88.9	114.3	101.6	140	22	64	25	9.4	12.7	0.8	F03
¾"	600	15.8	101.6	127	114.3	140	24.5	68	25	15.8	19.1	1	F03
1"	600	22.1	114.3	139.7	127	170	31	87	50.4	22.1	25.4	2	F04
1½"	400	34.8	139.7	165.1	152.4	200	44	112	50.4	34.8	38.1	5	F05
2"	400	47.5	165.1	190.5	177.8	230	53	122	63.9	47.5	50.8	8.5	F05
2½"	400	60.2	190.5	215.9	203.2	350	71.5	169	77.4	60.2	63.5	16	F07
3"	400	72.9	215.9	241.3	228.6	350	82.5	179	90.9	72.9	76.2	22	F07
4"	300	97.4	254	279.4	266.7	450	101	198	118.9	97.4	101.6	40	F10
6"	150	146.9	355.6	381	368.3	500	144	260	166.9	146.9	152.4	100	F14

DIN	PN	BORE	A1	A2	A3	B	C	D	E	F	G	kg	ISO 5211
10	100	10	90	115	102.5	140	22	64	34	10	13	0.8	F03
15	100	16	100	125	112.5	140	24.5	68	34	16	19	1	F03
20	100	20	115	140	127.5	170	31	87	34	20	23	2	F04
25	64	26	125	150	137.5	170	36	92	50.5	26	29	3	F04
32	64	32	140	165	152.5	200	44	112	50.5	32	35	5	F05
40	64	38	150	175	162.5	200	47	117	50.5	38	41	6	F05
50	64	50	165	190	177.5	230	53	122	64	50	53	8.5	F05
65	64	62	190	215	202.5	350	71.5	169	91	66	70	16	F07
80	64	75	215	240	227.5	350	82.5	179	106	81	85	22	F07
100	40	97	255	280	267.5	450	101	198	119	100	104	40	F10
150	16	147	355	380	367.5	500	144	260	183	150	154	100	F14

ISO 1127 TUBE dimensions available upon request

XP Series

2 Way Floating
Investment Cast

The XP Series is a sanitary floating ball valve designed for Pharmaceutical and Food & Beverage applications where high purity, drainability and cleanability are extremely important to ensure high levels of process quality and performance.

Welding connections are provided as standard in A351 CF3M with controlled sulphur and ferrite content below 3% to improve weldability and avoid corrosion.

Non-metallic parts comply with FDA, USP cl VI, ROHS, BSE/TSE and others to guarantee the suitability of the valves to the processes. External mill finishing and internal mechanical polishing matching SF0 and SF1, provided as standard, makes this high-tech investment cast series the best solution to meet the requirements of the technical room applications.

A better internal mechanical polishing and electropolishing matching SF4 finishing is available upon request.

RP valves are autoclavable at 121 °C x 20 minutes

ASME BPE TUBE (O.D)

Tube Bore: ½" to 6"

DIN 11850 R2 TUBE

Tube Bore: 10 to 50
Full Bore: 65 to 150

ISO 1127 TUBE

Tube Bore: 8 to 50
Full Bore: 10 to 100

DESIGN TEMPERATURE

-50°C to 200°C

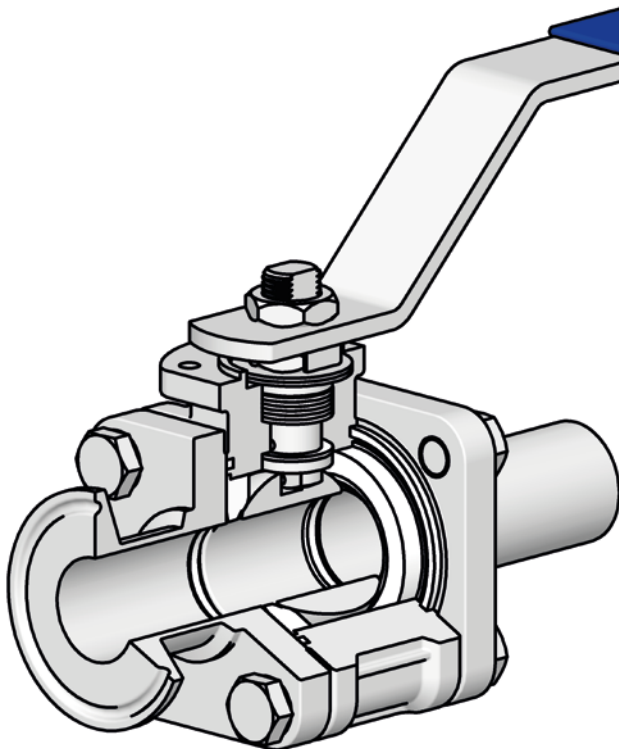

PART		STANDARD STAINLESS STEEL	OPTIONAL* ALLOY STEEL
Body / Ends		A351 CF3M (316L)	A494 CW-12MW (Alloy 276)
TRIM	Ball	A351 CF3M (316L)	B574 N10276 (Alloy 276)
	Stem	A479 316/L	B574 N10276 (Alloy 276)
Seats		TFM1600	
Packing & Seals		TFM1600 & PTFE	
Bolting		A2 cl. 70 (304)	A4 cl. 70 (316)
SURFACE FINISH			
STANDARD		OPTIONAL	
INTERNAL FINISH 0.51 µm / 20 µin (SF1)		INTERNAL FINISH 0.38 µm / 15 µin (SF4)	
EXTERNAL FINISH mill finish (SF0)			

*Others available upon request

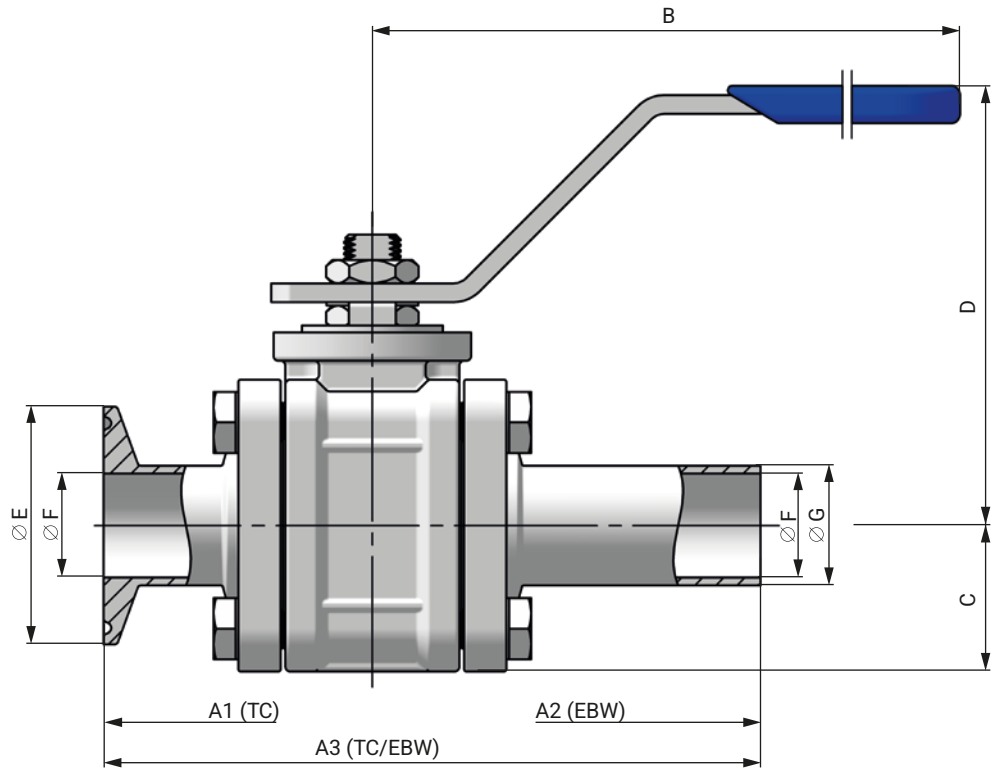

ASME	CLASS	BORE	A1	A2	A3	B	C	D	E	F	G	kg	ISO 5211
½"	600	9.4	88.9	139.7	114.3	140	22.5	64	25	9.4	12.7	0.7	F03
¾"	600	15.8	101.6	152.4	127	140	25.5	68	25	15.8	19.1	1	F03
1"	600	22.1	114.3	165.1	139.7	170	31.5	87	50.4	22.1	25.4	2	F04
1½"	400	34.8	139.7	190.5	165.1	200	42.5	112	50.4	34.8	38.1	4	F05
2"	400	47.5	165.1	215.9	190.5	230	53.5	122	63.9	47.5	50.8	7.5	F05
2½"	400	60.2	190.5	241.3	215.9	350	73	169	77.4	60.2	63.5	13.5	F07
3"	400	72.9	215.9	266.7	241.3	350	83.5	179	90.9	72.9	76.2	18.5	F07
4"	300	97.4	254	304.8	279.4	500	101.5	209	118.9	97.4	101.6	31	F10
6"	150	146.9	368.3	419.1	393.7	500	153	308	166.9	146.9	152.4	88.5	F14

DIN	PN	BORE	A1	A2	A3	B	C	D	E	F	G	kg	ISO 5211
10	100	10	90	140	115	140	22.5	64	34	10	13	0.7	F03
15	100	16	100	150	125	140	25.5	68	34	16	19	1	F03
20	100	20	115	165	140	170	31.5	87	34	20	23	2	F04
25	64	26	125	175	150	170	36.5	92	50.5	26	29	2.5	F04
32	64	32	140	190	165	200	42.5	112	50.5	32	35	4	F05
40	64	38	150	200	175	200	47.5	117	50.5	38	41	5.5	F05
50	64	50	165	215	190	230	53.5	122	64	50	53	7.5	F05
65	64	62	190	240	215	350	73	169	91	66	70	13.5	F07
80	64	75	215	265	240	350	83.5	179	106	81	85	18.5	F07
100	40	97	255	305	280	500	101.5	209	119	100	104	31	F10
150	16	147	370	420	395	500	153	308	183	150	154	88.5	F14

ISO 1127 TUBE dimensions available upon request

LP Series

2 Way Floating
Investment Cast

The LP Series is a sanitary floating ball valve designed for Pharmaceutical and Food & Beverage applications where high purity, drainability and cleanability are extremely important to ensure high levels of process quality and performance.

Welding connections are provided as standard in A351 CF3M with controlled sulphur and ferrite content below 3% to improve weldability and avoid corrosion.

Non-metallic parts comply with FDA, USP cI VI, ROHS, BSE/TSE and others to guarantee the suitability of the valves to the processes. External mill finishing and internal mechanical polishing matching SF0 and SF3, provided as standard, makes this standard investment cast series the most economic solution to meet the requirements of the technical room applications.

A better internal mechanical polishing and electropolishing matching SF5 finishing is available upon request.

ASME BPE TUBE (O.D)

Tube Bore: ½" to 2"

DESIGN TEMPERATURE

-50°C to 200°C

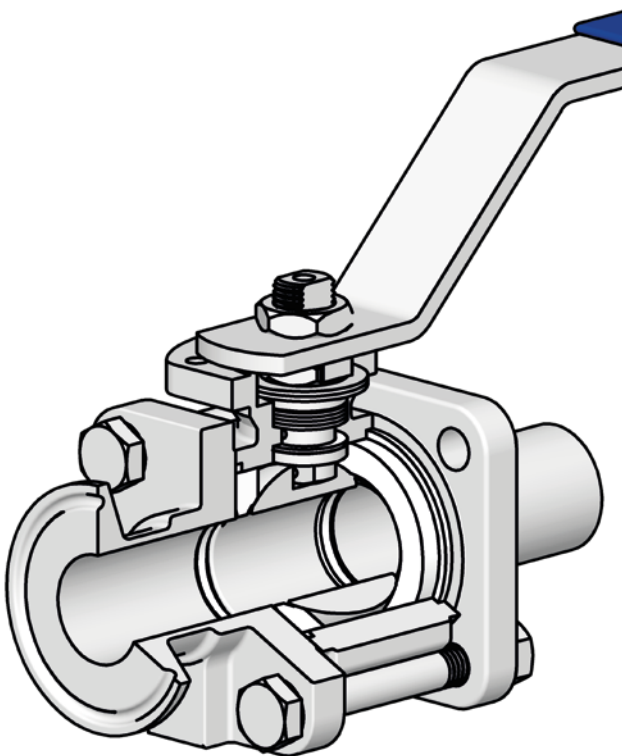

PART		STANDARD STAINLESS STEEL
	Body / Ends	A351 CF3M (316L)
TRIM	Ball	A351 CF3M (316L)
	Stem	A479 316/L
	Seats	PTFE
	Packing & Seals	TFM1600 & PTFE
	Bolting	A2 cl. 70 (304)
SURFACE FINISH		
	STANDARD	OPTIONAL
	INTERNAL FINISH 0.76 µm / 30 µin (SF3)	INTERNAL FINISH 0.51 µm / 20 µin (SF5)
	EXTERNAL FINISH mill finish (SF0)	

*Others available upon request

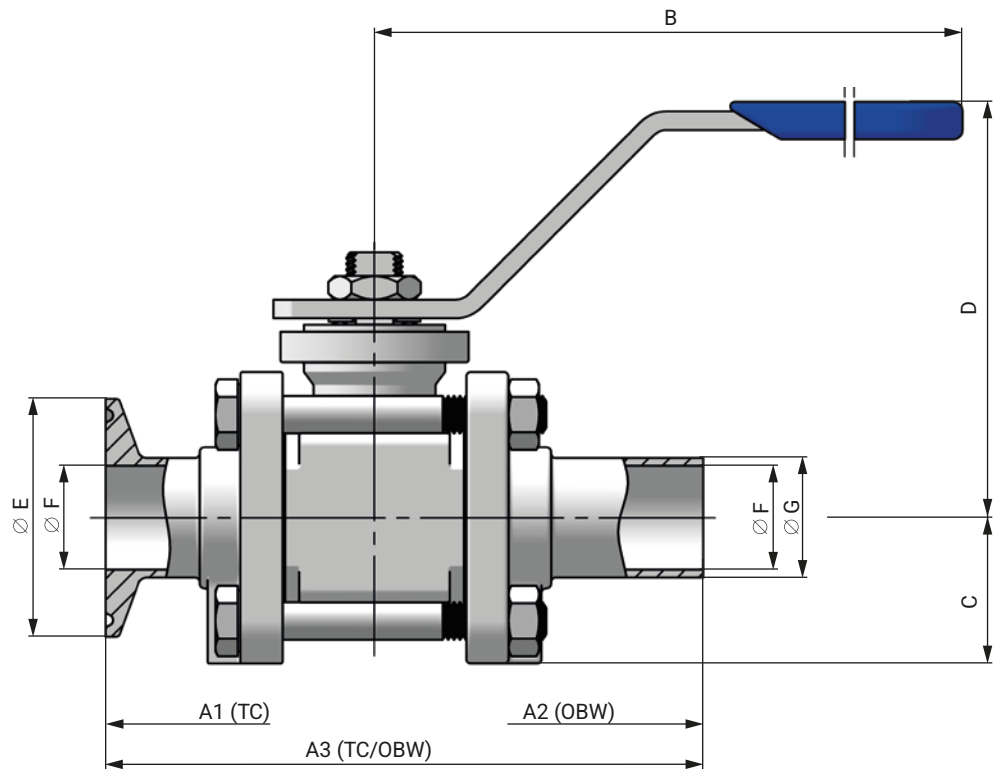

ASME	CLASS	BORE	A1	A2	A3	B	C	D	E	F	G	kg	ISO 5211
½"	600	9.4	88.9	114.3	101.6	140	21	64	25	9.4	12.7	0.6	F03
¾"	600	15.8	101.6	127	114.3	140	25	68	25	15.8	19.1	0.8	F03
1"	600	22.1	114.3	139.7	127	170	31	87	50.4	22.1	25.4	1.5	F04
1½"	400	34.8	139.7	165.1	152.4	200	42	112	50.4	34.8	38.1	3.5	F05
2"	400	47.5	165.1	190.5	177.8	230	53	122	63.9	47.5	50.8	6.5	F05

MP Series

Multiport Floating
Barstock / Forging

The MP Series is a sanitary floating ball valve designed for Pharmaceutical and Food & Beverage applications where high purity, drainability and cleanability are extremely important to ensure high levels of process quality and performance.

Welding connections are provided as standard in A479 316L with controlled sulphur and ferrite content below 0.5% to improve weldability and avoid corrosion.

Non-metallic parts comply with FDA, USP cl VI, ROHS, BSE/TSE and others to guarantee the suitability of the valves to the processes. External and internal mechanical polishing matching SF3 and SF1, provided as standard, makes this high-tech mirror polished series

the best solution for maximum cleanliness requirements of the clean room applications.

A better internal mechanical polishing and electropolishing matching SF4 finishing is available upon request.

ASME BPE TUBE (O.D)

Tube Bore: ½" to 2"

DIN 11850 R2 TUBE

Tube Bore: 10 to 50

ISO 1127 TUBE

Tube Bore: 8 to 40

Full Bore: 10 to 50

DESIGN TEMPERATURE

-50°C to 200°C

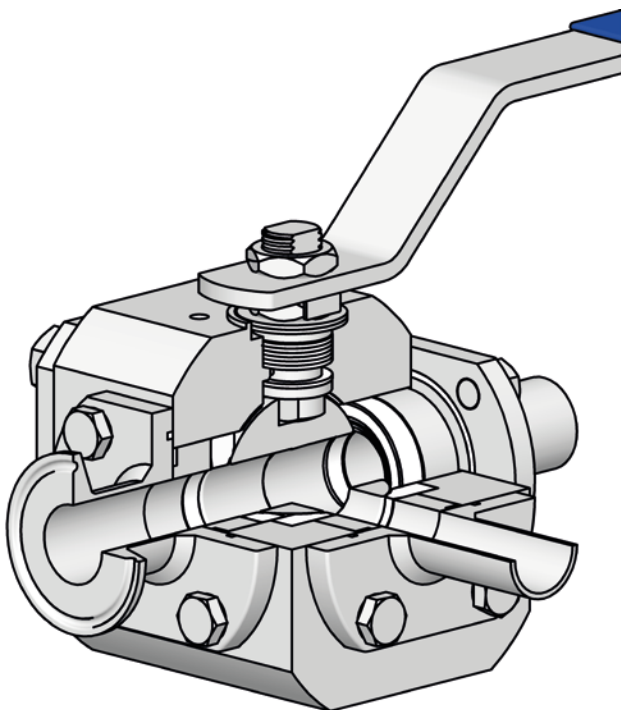

PART		STANDARD STAINLESS STEEL	OPTIONAL* ALLOY STEEL
Body / Ends		A479 316/L	B574 N06022 (Alloy 22)
TRIM	Ball	A479 316/L	B574 N06022 (Alloy 22)
	Stem	A479 316/L	B574 N06022 (Alloy 22)
Seats		TFM1600	
Packing & Seals		TFM1600 & PTFE	
Bolting		A2 cl. 70 (304)	A4 cl. 70 (316)
SURFACE FINISH			
STANDARD		OPTIONAL	
INTERNAL FINISH 0.51 µm / 20 µin (SF1)		INTERNAL FINISH 0.38 µm / 15 µin (SF4)	
EXTERNAL FINISH 0.76 µm / 30 µin (SF3)			

*Others available upon request

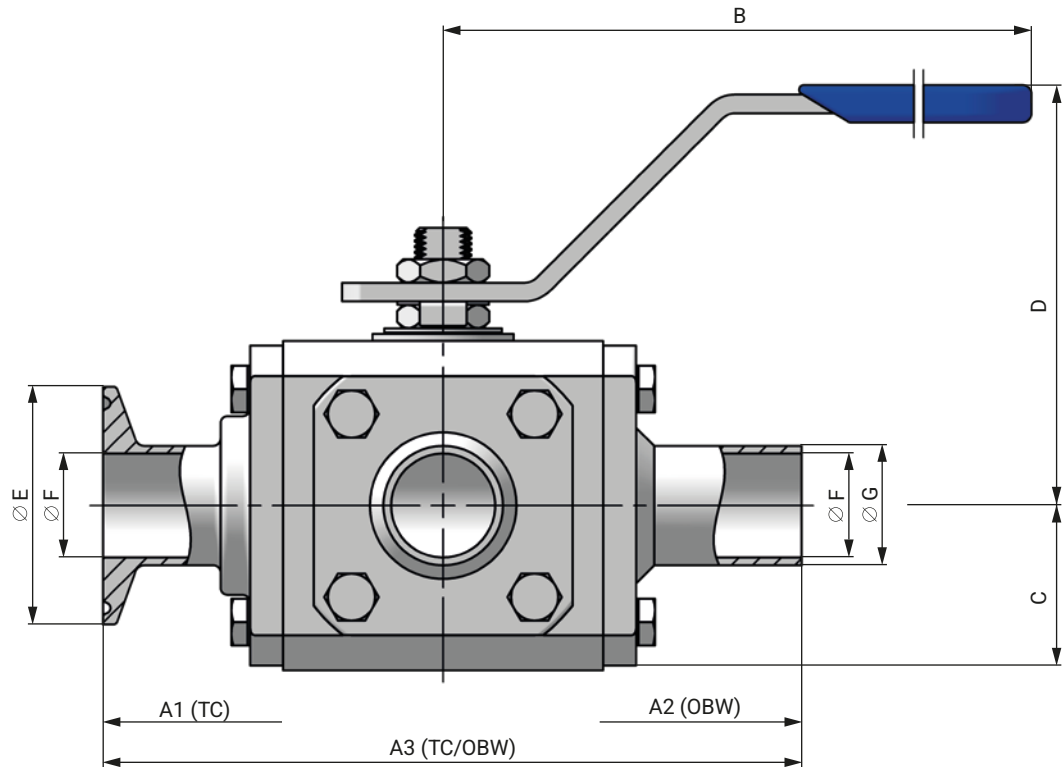

ASME	CLASS	BORE	A1	A2	A3	B	C	D	E	F	G	kg	ISO 5211
½"	600	9.4	133.4	158.8	146.1	170	35	90	25	9.4	12.7	3.6	F04
¾"	600	15.8	139.7	165.1	152.4	170	35	90	25	15.8	19.1	4	F04
1"	600	22.1	165.1	190.5	177.8	200	46	110	50.4	22.1	25.4	7.5	F05
1½"	400	34.8	203.2	228.6	215.9	230	59	130	50.4	34.8	38.1	15.5	F05
2"	400	47.5	266.7	292.1	279.4	350	85	170	63.9	47.5	50.8	40.5	F07

DIN	PN	BORE	A1	A2	A3	B	C	D	E	F	G	kg	ISO 5211
10	100	10	135	160	147.5	170	35	90	34	10	13	3.6	F04
15	100	16	140	165	152.5	170	35	90	34	16	19	4	F04
20	100	20	165	195	180	200	46	110	34	20	23	7.5	F05
25	64	26	170	195	182.5	200	46	110	50.5	26	29	8	F05
32	64	32	205	230	217.5	230	59	130	50.5	32	35	15.5	F05
40	64	38	205	230	217.5	230	59	130	50.5	38	41	16	F05
50	64	50	265	290	277.5	350	85	170	64	50	53	40.5	F07

ISO 1127 TUBE dimensions available upon request

QP Series

Multiport Floating
Investment Cast

The QP Series is a sanitary floating ball valve designed for Pharmaceutical and Food & Beverage applications where high purity, drainability and cleanability are extremely important to ensure high levels of process quality and performance.

Welding connections are provided as standard in A351 CF3M with controlled sulphur and ferrite content below 3% to improve weldability and avoid corrosion.

Non-metallic parts comply with FDA, USP cl VI, ROHS, BSE/TSE and others to guarantee the suitability of the valves to the processes. External mill finishing and internal mechanical polishing matching SF0 and SF1, provided as standard, makes this high-tech investment cast series the best solution to meet the requirements of the technical room applications.

A better internal mechanical polishing and electropolishing matching SF4 finishing is available upon request.

ASME BPE TUBE (O.D)

Tube Bore: ½" to 2"

DIN 11850 R2 TUBE

Tube Bore: 10 to 50

ISO 1127 TUBE

Tube Bore: 8 to 40

Full Bore: 10 to 50

DESIGN TEMPERATURE

-50°C to 200°C

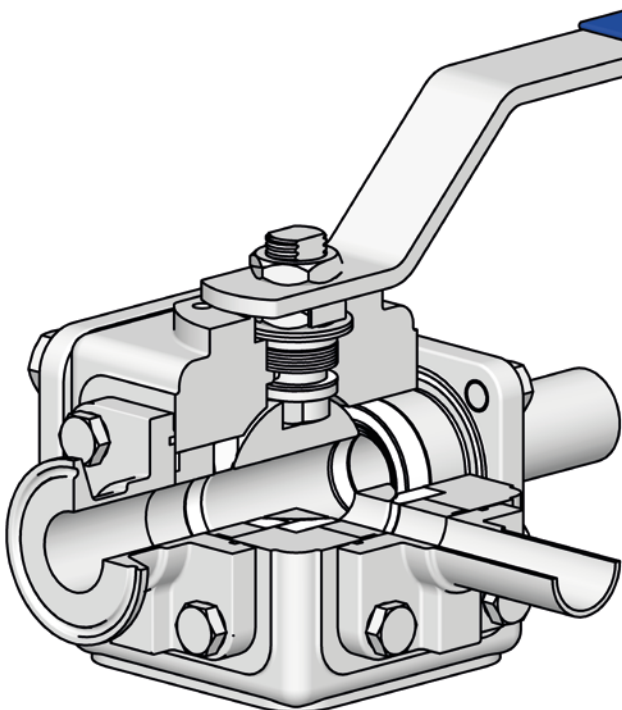

PART		STANDARD STAINLESS STEEL	OPTIONAL* ALLOY STEEL
Body / Ends		A351 CF3M (316L)	A494 CW-12MW (Alloy 276)
TRIM	Ball	A351 CF3M (316L)	B574 N10276 (Alloy 276)
	Stem	A479 316/L	B574 N10276 (Alloy 276)
Seats		TFM1600	
Packing & Seals		TFM1600 & PTFE	
Bolting		A2 cl. 70 (304)	A4 cl. 70 (316)
SURFACE FINISH			
STANDARD		OPTIONAL	
INTERNAL FINISH 0.51 µm / 20 µin (SF1)		INTERNAL FINISH 0.38 µm / 15 µin (SF4)	
EXTERNAL FINISH mill finish (SF0)			

*Others available upon request

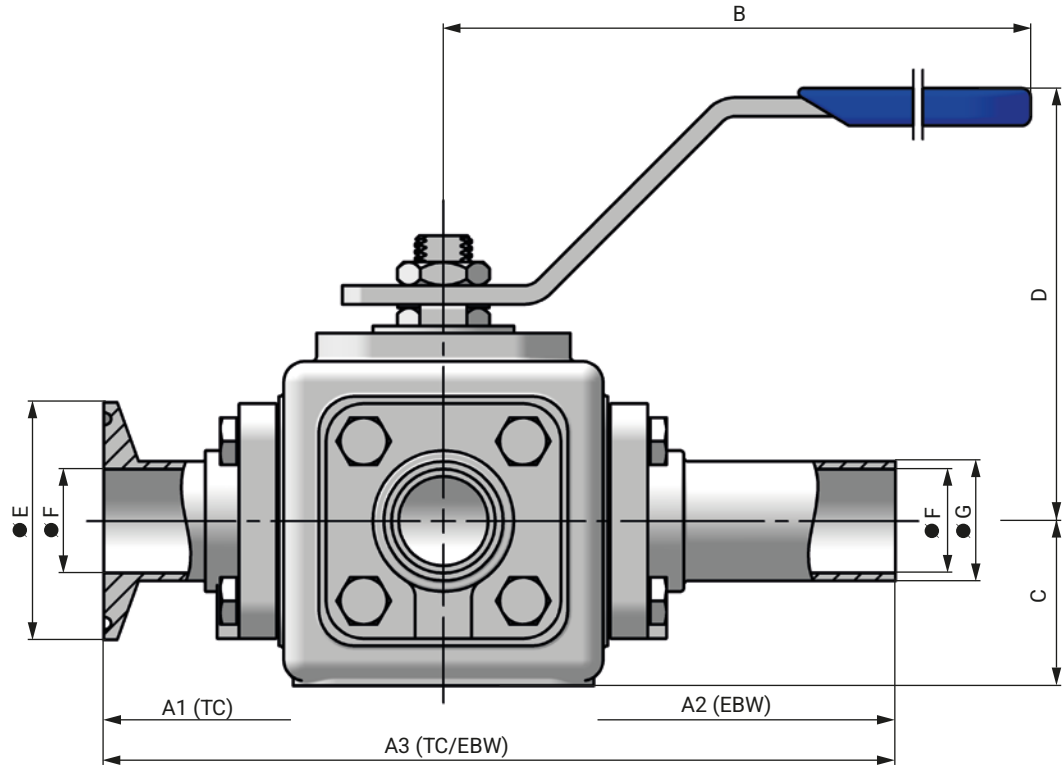

ASME	CLASS	BORE	A1	A2	A3	B	C	D	E	F	G	kg	ISO 5211
½"	600	9.4	133.4	184.2	158.8	170	35	90	25	9.4	12.7	3.3	F04
¾"	600	15.8	139.7	190.5	165.1	170	35	90	25	15.8	19.1	3.5	F04
1"	600	22.1	165.1	215.9	190.5	200	46	110	50.4	22.1	25.4	7.2	F05
1½"	400	34.8	203.2	254	228.6	230	59	130	50.4	34.8	38.1	14.5	F05
2"	400	47.5	266.7	317.5	292.1	350	85	170	63.9	47.5	50.8	40	F07

DIN	PN	BORE	A1	A2	A3	B	C	D	E	F	G	kg	ISO 5211
10	100	10	135	185	160	170	35	90	34	10	13	3.3	F04
15	100	16	140	190	165	170	35	90	34	16	19	3.5	F04
20	100	20	165	215	190	200	46	110	34	20	23	7.2	F05
25	64	26	170	220	195	200	46	110	50.5	26	29	7.5	F05
32	64	32	205	255	230	230	59	130	50.5	32	35	14.5	F05
40	64	38	205	255	230	230	59	130	50.5	38	41	15	F05
50	64	50	265	315	290	350	85	170	64	50	53	40	F07

ISO 1127 TUBE dimensions available upon request

MANUAL OPERATION

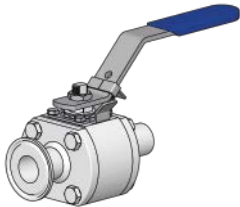

Lockable Handle

The lockable handle is a safety device that prevents the unintended rotation of the obturator due to vibrations, turbulent flows or unauthorized actions leading to potentially severe malfunctions in the process. This occurrence can be prevented by the application of a lockable mechanism to prevent the valve from closing or opening.

Small sizes are equipped with a trigger that allows to lock the position of the handle in closed or open position without the need of a padlock. Nevertheless, all sizes can be equipped with a padlock.

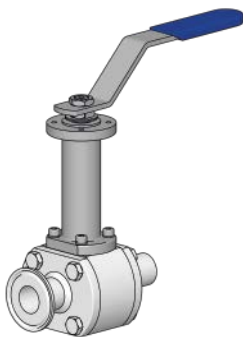

Stem Extension

Inaccessible locations, insulation of the piping, extreme temperatures and others are usually conditions found in several processes where easier operation solutions are required. In these kind of applications, a stem extension can be the solution to decrease the restrictions and insure the safe operation of the processes.

The standard stem extension is equipped with a secondary stem packing system containing eventual emissions to the atmosphere. Other options are also available upon request.

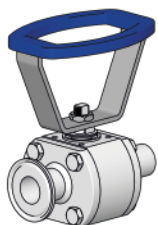

Oval Handle

The standard handle is sometimes too long to fit in tiny spaces that are available for the valves in a process. An oval handle could be the best way to reduce the size of the valve without losing the operation capabilities. This solution strongly decreases the surrounding space needed for each valve improving the compactness of the installation.

AUTOMATIC OPERATION

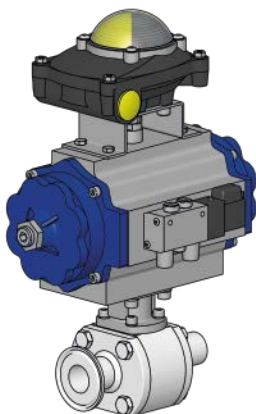

Bracket and Actuator

Automation of the processes is a growing and necessary investment to reduce the manual interventions, which will prevent the eventual mistakes by a manual operation and enhance the processes to better performances.

Following these requirements, the valves can also be fully automated. For instance, the valve can be equipped with a pneumatic actuator, a solenoid valve and a limit switch. These accessories will allow the remote actuation of the valve and the control of its position.

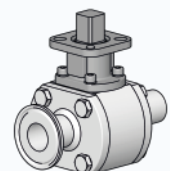

SPECIFIC APPLICATIONS

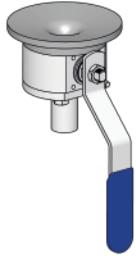

Tank Bottom

Pressure vessels are used in several processes and need, time to time, to be drained or cleaned. The best solution for this kind of operation is the application of a tank bottom valve, also called as flush bottom valve, which can be easily installed at the bottom of the vessels and allows a fast drainage of the tank.

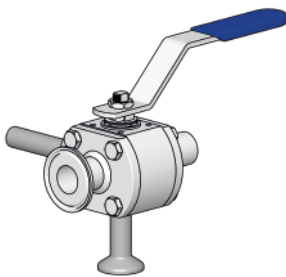

CIP/ SIP Purge Port

High purity processes demand reliable solutions to guarantee the quality of the media. Sterilization (CIP/SIP) of the valves is normally performed to meet these requirements. The valves used for this application can be equipped with additional connections, allowing the cleaning of all interior surfaces without removing it from the installation. This allows more systematic preventive maintenance with minimum downtime, enhancing the cost savings.

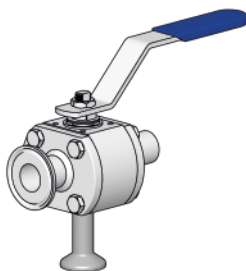

Steam Trap

Steam is used in processes as a heating or mechanical inducer due to its high latent energy capacity. As the steam delivers its energy to the process, it condensates losing the ability to transfer energy as efficiently as in the steam condition. At this point it is important to drain the condensates to maximize the performance of the line. The installation of steam trap valves may be the solution as they will permit to drain the condensates without releasing the steam, reducing the cost of the process.

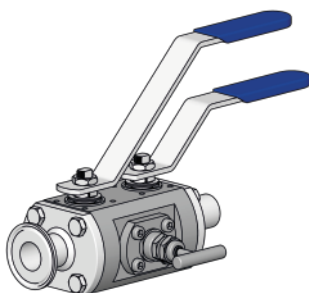

Double Block and Bleed

Some processes require repetitive sampling for analysis to guarantee high quality levels of the process products. The best way to achieve this is the installation of a DBB valves. This kind of valves consists of two ball valves used to trap the fluid and a middle valve used to extract the sample. With this kind of valves, usually applied as a forked section, it is possible to trap and remove a sample from the system without stopping the process. This valve type is also frequently used for instrumentation protection.

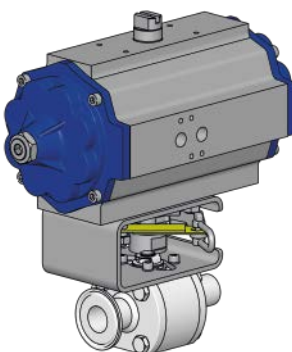

Fire Fail Safe

Flammable gases and chemicals are often used in processes across several industries. To prevent the widespread of a fire event in these facilities, a fire fail safe valve may be used as a safety device, which will trigger an automatic emergency shutoff. The fire fail safe valve is designed to be activated at the set temperature of the system by the fusible link breakage. This breakage will lead to the line shutoff.



NEUMO

NEUMO Ehrenberg Group



+34 977 524 914



+34 977 524 898



neumo-es@neumo-es.com

www.neumo-es.com